

Designing Electric Vehicle Battery Charging

**Prof. Geetanjali Jichkar¹, Prof. Chandani Suryavanshi², Pallavi R. Bisen³, Laxmi Ravindra Raut⁴,
Rupali Sawalram Rahangdale⁵**

¹Project Guide, Department of Electronics and Telecommunication Engineering, Madhukarrao Pandav Collage Of Engineering, Bhilewada, Bhandara.

²HOD, Department of Electronics and Telecommunication Engineering, Madhukarrao Pandav Collage Of Engineering, Bhilewada, Bhandara.

^{3,4,5}Student, Department of Electronics and Telecommunication Engineering, Madhukarrao Pandav Collage Of Engineering, Bhilewada, Bhandara.

Abstract -

A pioneering technology for electric vehicle power converters is the double-star modular multilevel converters with embedded battery cells. In this topology, the battery cells are connected in series via half bridge DC–DC buck converters, enabling independent discharge and recharge. This paper presents a novel control system designed specifically for this converter topology. The proposed control system aims to charge the battery cells from the grid at unity power factor while simultaneously balancing their state of charges, all without impacting grid voltages and currents. The grid current controller is developed and implemented in the stationary reference frame using a proportional-resonant controller. Meanwhile, the state of charge balancing algorithm is designed using a sorting algorithm and circulating current control. Simulation and experimental results validate the effectiveness of the proposed control strategy. They demonstrate that the strategy can charge the battery cells with minimal distortion of the grid current and ensure cell balance during recharge without affecting grid current.

Keywords: *Electric Vehicle, Battery Charging, LCD display, Solar Panel etc.*

1. INTRODUCTION

India is the world's third largest producer and third largest consumer of electricity. Energy use has doubled since 2000, with 80% of demand still being met by coal, oil and solid biomass (Fossil Fuel). Share of Renewable energy is around 20%. According to NITI Aayog's energy policy report, India's demand for energy is expected to double by 2040, and that for electricity to potentially triple as a result of increased ownership of electric vehicles. As electric vehicles are going to increase in future, this will create heavy load on electricity demand in future. There should be development of charging infrastructure for electric vehicles, which should be operated with the help of renewable energy. Solar charging stations is the best option.

First, electrification will change our global energy consumption habits from the need for fuels that are burned on site - gasoline, oil, natural gas and others - to the need to use electricity. This means that our country's demand for fossil fuels will decrease, while our overall electricity demand will increase. Solar power generation is very influential in India. The geographical location of the country is favourable for the production of solar energy. The reason is that India is a tropical country and receives solar radiation almost all year round, which amounts to 3,000 hours of sunshine yearly. The use of solar power can reduce our dependency on fossil fuels for electricity generation.

At present, the power converters used in Battery Electric Vehicles (BEVs) are traditional 2-level voltage-source inverters. The DC link of the inverter is connected to the battery pack, which consists of a series connected low voltage cells to reach the required DC voltage. Due to the series connection of the cells, the charging and discharging process causes a state of charge (SOC) imbalance, as cells have different leakage currents and electrochemical characteristics; this may damage the cells and reduce their lifetime. For this reason, a battery management system (BMS) is used to balance the cells by shifting the energy from the cells with highest SOC's to the cells with lowest SOC's. However, the BMS increases the size and cost of the BEV and reduces the efficiency of the conversion system. Additionally, the output waveform of a 2-level inverter has a significant harmonic content. Therefore, the inverter can be used also for battery charging only if passive L or LCL bulky filters are added between the converter and the grid. Also, the converter does not allow single-phase or DC charging.

2. PROBLEM DEFINATION

The transport sector generates more than 35% of total CO₂ emissions. As you can see in the current scenario the electric vehicles are the future of every transport system and the demand for electric vehicles are growing tremendously. The government is also supporting the electric vehicle system and big company like Tata is investing huge on electric charging stations across India. The electricity generation in

India is still depends on coal, oil and biomass was with the contribution of more than 80%. So, to make the electric vehicle system complete green solution there is a demand to make the solar powered EV charging system. So here in this report the complete design of solar charging station for electric vehicle is done. The parameter considered for designing the charging station are the efficiency of solar panel and its types, with detailed study of charge controller and battery. The complete design of solar panel its type and size are calculated and also the area required for charging the electric vehicles.

3. AIM AND OBJECTIVES

The main objective of the project is to design the EV charging station for actual available car model in Indian market considering all the parameter like sun light availability, charging area required for solar panel, battery and power calculation and considering each and every parameter about charging and equipment. The design should be such that after referring the document user should be able to install the solar EV station very easily. And also, to avoid local grid overload and guarantee a higher percentage of clean energy, EV charging stations can be supported by a combined system of grid-connected photovoltaic modules and battery storage.

4. LITERATURE REVIEW

One Before Elangovan , Deepa , Maheshwari (2015) discuss about the efficient utilization of solar energy using SLC. The presented SLC is closed loop controlled using FPGA Spartan 6 processor. The suggested SLC influences the quality of DC link voltage and transfer gain. The attained DC link voltage is three times greater than that of the voltage from the PV array. Also, the ripple content in the DC link voltage is less than 1%.

Pavan, Vijayendra, Shashikala (2015) present a proposed charging station microgrid model for off-grid EV charging station with the integration of renewable energies such as solar photovoltaic, wind, Fuel Cell with provision for storage with mainly battery and optional storage with ultra-capacitors has been presented. Vishal,

Vaidya, Kaiwalya. Kulkarni (2015) have done the team’s research indicated a benefit to the campus for such a structure and also room for improvement on other existing charging stations. Other stations the team found were quite expensive to build. Additionally, solar designs and innovations are rapidly advancing which could contribute to a more efficient charging station.

Simon Steinschaden and José Baptista (2015) discuss about the tool has been developed to help find solutions for each combination of charging station properties, most efficient combination. It emerges that solar charging stations for private and commercial use can be design. In summary, due to the ease of management and simplicity of the tool compared to

alternative computing software, this tool is suitable to suit a wide range of audience groups including professionals and non-professionals. However, all the necessary parameters for the design of a solar charging station are taken into account. The results are comparable with solar power design, self-sufficiency rate, self-expenditure and payback period.

Gheorghe Badea, Raluca-Andreea, Felseghi (2015) examines the possibility of charging electric vehicle batteries with clean energy using solar autochthonous renewable resources. At the charging station of a photovoltaic module and battery-based electric vehicle, an island system was designed, sized, and simulated in operation. The optimal configuration of the photovoltaic system was supplemented with Hybrid Optimization software enhanced by Genetic Algorithm (iHOGA) version 2.4 and we simulated its operation. The solar power system should be designed so that the charging station always has enough electricity to power multiple electric vehicles 24 hours a day.

5. SYSTEM ARCHTECTURE

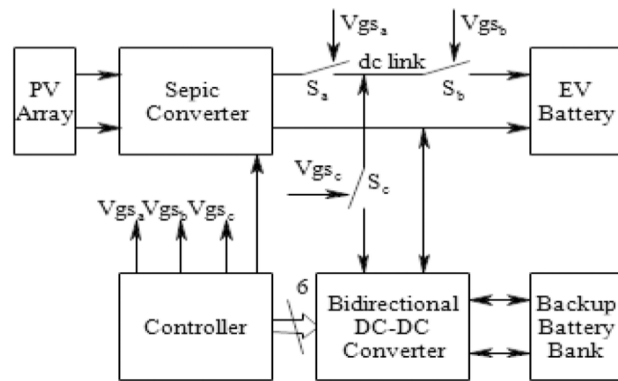

Figure.1 Pictorial representation of the System

An electric vehicle battery (EVB, also known as a traction battery) is a rechargeable battery used to power the electric motors of a battery electric vehicle (BEV) or hybrid electric vehicle (HEV.)

EV charging involves supply of direct current (DC) to the battery pack. As electricity distribution systems supply alternate current (AC) power, a converter is required to provide DC power to the battery. Conductive charging can be AC or DC.

Zero emission electric vehicles (EVs) are an attractive alternative to conventional internal combustion vehicles due to the increase of fuel price in the world and the effect of CO2 emissions on the environment.

Hardware Specifications

- EMI
- AC DC controller
- EV Battery
- Sepic convertor
- AV Array
- Rectifier
- Amplifier.

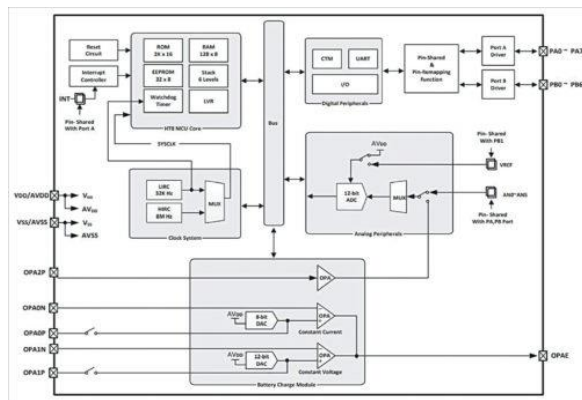

Figure.2. EV Charger Circuit Diagram

6. APPLICATION OF EV CHARGING

- Electric vehicles, in one form or another, have been around for over 100 years.
- Early vehicles used lead acid batteries and worked at 6V and upwards.
- The basic lead battery charger consists of an AC to DC converter and some, often simple, circuitry to control the charging voltage and current to a level suitable for the battery configuration.

7. ADVANTAGES & BARRIERS OF EV BATTERY CHARGING

Application

- EV recharging is completed in minutes.
- Batteries can be charged away from swapping point, allowing more freedom in setting up swap facilities.
- Reduction in upfront cost of EV, as battery ownership is replaced by battery leasing.
- Increased predictability of battery life due to controlled charging conditions.

Barriers

- Lack of standardization among EV batteries.
- Unsuitable battery pack design to enable ease of swapping.
- Greater number of batteries needed to power same number of EVs.
- Higher costs of battery leasing over the life of the EV.

8. CONCLUSION

As we know 21 cities amongst world’s 30 most polluted cities are from India and India stands 5th in the most polluted countries list. The electricity generation sector is currently the greatest carbon emitter in India. Also, carbon particulates emissions from the automobile sector are rapidly increasing due to increase in the number of gasolines powered vehicles. The effective control of pollution from these two emerging sectors is related to the greatest achievement of pollution control objectives. Thus, this paper tries to develop a model that combines solar powered charging stations for Electric Vehicles and use of EV’s to simultaneously reduce pollution from the power generation sector and automobile sector.

REFERENCES

[1] G.R. Chandra Mouli, P. Bauer, M. Zeman Department of Electrical Sustainable Energy, Delft University of Technology. “System design for a solar powered electric vehicle charging station”.

[2] Bagher1, Mirzaei Mahmoud Abadi Vahid2, Mirhabibi Mohsen1 “Types of Solar Cells and Application”. American Journal of Optics and Photonics 2015; 3(5): 94-113 Published online August 21, 2015 doi: 10.11648/j.ajop.20150305.17 ISSN: 2330-8486 (Print); ISSN: 2330-8494 (Online)

[3] Huaizhong Chen” Design of a New Type of Charging Station for Solar Electric Vehicle”. Zhejiang Industry Polytechnic College, Shaoxing, China.

[4] Simon Steinschaden 1 and José Baptista 2 “Development of an efficient tool for solar charging station for electric vehicles”. Published: 10 June 2020. [5] Bin Ye 1, Jingjing Jiang 2,3, Lixin Miao 1, Peng Yang 1, Ji Li 3 and Bo Shen 4. “Feasibility Study of a SolarPowered Electric Vehicle Charging Station Model”. Published: 23 November 2015.

[6] Xusheng Liang, Elvis Tanyi, Xin Zou. “Charging electric cars from solar energy”. Department of Electrical Engineering, Blekinge Institute of Technology, Karlskrona, Sweden,2016.

[7] Prof.Vishal K. Vaidya1, Kaiwalya S. Kulkarni2, Mahesh B. Patil3, Onkar V. Bhole4, Kedar P. Pathak5. “Solar based Electric Vehicle Smart Charging Station”. (IRJET) Mar 2020.

[8] P.Manimekalai, R.Harikumar, S.Raghavan, “An Overview of Batteries for Photovoltaic (PV) Systems” International Journal of Computer Applications (0975 – 8887). Volume 82 – No 12, November 2013

- [9] Stephen Lee, Srinivasan Iyengar, David Irwin, Prashant, "Shared Solar-powered EV Charging Stations: Feasibility and Benefits".
- [10] Hassan Fathabadi, "Novel solar powered electric vehicle charging station with the capability of vehicle-to-grid". journal homepage:
- [11] Kondracki, Ryan; Collins, Courtney; Habbab, Khalid, "Solar Powered Charging Station". ASEE 2014 Zone I Conference, April 3-5, 2014, University of Bridgeport, Bridgeport, CT, USA.
- [12] Shruti Sharma, Kamlesh Kumar Jain, Ashutosh Sharma a review on "Solar Cells: In Research and Applications", Materials Sciences, 2015, 6, 1145-1155 Published December 2015
- [13] Askari Mohammad Bagher, Mirzaei Mahmoud Abadi Vahid, Mirhabibi. "Types of Solar Cells and Application". American Journal of Optics and Photonics. Vol. 3, No. 5, 2015, pp. 94-113. doi: 10.11648/j.ajop.20150305.17
- [14] Book of "Wind and Solar Power Plants" by M. Patel, CRC Press.
- [15] N. Gupta, G. F. Alapatt, R. Podila, R. Singh, K.F. Poole, (2009). "Prospects of Nanostructure-Based Solar Cells for Manufacturing Future Generations of Photovoltaic Modules". International Journal of Photo energy 2009: 1. doi:10.1155/2009/154059.