

Digital Notice Board with Keyboard

Sagar G. Kanoje¹ Nikhil B. Pardhi² Ankit D. Lede³ Abhishek S. Meshram⁴ Seema Biranware⁵

^{1,2,3,4}Student ⁵Assistant Professor

^{1,2,3,4,5}Department of Electronics and Telecommunication Engineering

^{1,2,3,4,5}MPCE Bhilewada, Bhandara, 441904, India

Abstract— This project is meant to develop a keyboard scrolling message display for notice board. It also can be used to display latest information anywhere like colleges, shops, railway stations and other places. The information is transmitted using keyboard. Traditionally notice board is all about sticking information, but sticking various notices day-to-day may be a difficult process. An individual is required separately to require care of this notice board. This technique displays notices through a keyboard on notice boards. This technique are often implemented in many important places where latest information are can be displayed. For example if implemented in colleges all information for college students and college management to display any information. This technique also can be implemented in railway stations and airports to display information regarding the train and flight timings. This technique reduces the wastage of papers. The knowledge is shipped through a keyboard, which is interfaced to 8051 family microcontroller through MAX232 interface IC. An external memory connected to the microcontroller stores the data. An LCD is connected to the microcontroller to display the message during a continuous scrolling manner.

Keywords: 8051 Microcontroller. MAX232 Interface, Keyboard, Notice Board

I. INTRODUCTION

We normally use an easy static LED display to transfer a message. once we want to display large data, we use to change message for each few instances. Now scrolling displays are more preferred to static. By employing a preprogrammed controller, we will make LED display in scrolling way. We can also make LED to adoptable by using keyboards controller based system. Simple Outdoor LED Message Moving or Scrolling Sign Board, Electronic projects using LED Scroller Generator for outdoor digital signs, Marketable LED sign board with Message scrolling are the examples of the scrolling LED display.

An information display may be a way of providing information and/or is employed as an object for promotion. It can be seen during a sort of cardboard or tarpaulin at stores/shops, streamers and electronic display devices. But the arrival of latest technologies made the information in the electronic display the sort of an electronic display in the form of advertising and promotions. The ability to display a brief message are often useful application to be available for any business. A LED display panel is ideal for this application. It can be used for both indoor and outdoor which makes it universal fit any business or event. The LED display board is extremely efficient and price effective way to spread messages to thousands of individuals, without personal contact or door-to-door sales. LED may be a solid state light with several attractive properties for display application. It is chosen because the main component for displaying messages because, today LED is that the most energy efficiency

example as compared to incandescent light bulb. A LED light emit little or no heat and saves tons of energy, as 98 percent of the energy employed by a standard incandescent light can be lost as heat energy instead of light energy. A GSM based LED display board is a device for displaying messages by sending the message in the form of SMS through mobile unit.

II. PROPOSED SYSTEM

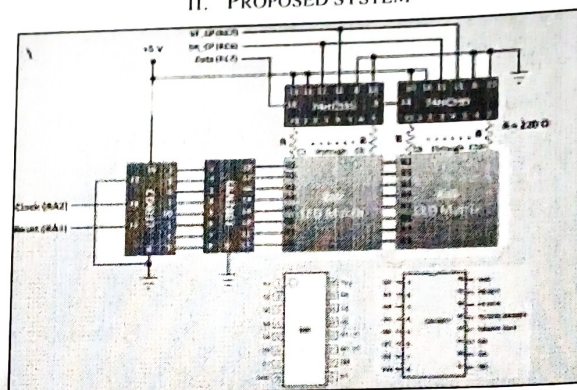

Fig. 1: LED Matrix with a Microcontroller and Shift Register Data

LED-based moving-message displays are becoming popular for transmitting information to large groups of people quickly. These can be used indoors or outdoors. We can find such displays in areas like railway platforms, banks, public offices, hotels, training institutes, nightclubs and shops. Compared to LEDs, liquid-crystal displays (LCDs) are easy to interface with a microcontroller for displaying information as these have many built-in functions. But these can't be observed from a distance and large-size LCDs are very costly. LED-based displays can be of two types: dot-matrix and segmental. If you implement a moving message display with multiplexed dot-matrix LEDs, it will be very costly for displaying 16 characters or more at a time. Moreover, programming will require a lot of data memory or program memory space. An external RAM may be needed to complement a microcontroller like AT89C51. However, if you use alphanumeric (16-segment LED) displays for the above purpose, programming burden is reduced and also it becomes highly cost-effective. You can make your own display panel consisting of 16 alphanumeric characters at a much lower cost. The circuit presented here uses 16 common-anode, single-digit, alphanumeric displays to show 16 characters at a time. Moreover, programming has been done to make the characters move in a beautiful manner. A message appears on the panel from the right side, stays for a few seconds when the first character reaches the leftmost place and then goes out from the left side. It displays 16 different messages to depict different occasions, which can be selected by the user through a DIP switch.

Design Foot Step Power Generation using Microcontroller

Pranay Ukey¹ Khushaldas Parshuramkar² Mayuri Bandebuche³ Ashwini Sakharwade⁴ Seema Biranware⁵

^{1,2,3,4}Student ⁵Assistant Professor

^{1,2,3,4,5}Department of Electronics and Telecommunication Engineering

^{1,2,3,4,5}MPCE Bhilewada, Bhandara, 441904, India

Abstract— Whenever people walk on foot step, they lose their energy, we have design such a mechanism in which we have used this waste energy to generate electricity. Foot step electricity generation as such is not a new concept. There were many attempts in the past pneumatics, piezoelectric materials etc, but all of them proved very costly and were not practically feasible in day-to-day real life. The persons, who are walking on foot step are applying the impact force or thrust on the spring loaded stair case steps. This impact pressure energy can be utilized to operate the energy flywheel through unit-directional ratchet arrangement using chain and sprocket wheel drive. The flywheel, which stores the energy and utilizes it for continuous rotation, rotate alternator that generate electricity. It is best use of non conventional source of energy, saving of coal and water for generating electricity, eco friendly, simple mechanism, easy for installation, easy for maintenance. It can be used on railway station, airports, shopping mall, jogging parks. The project is developed keeping in mind the idea of generating electricity from non-conventional means, which is free from pollution and can be used directly in real life, i.e. it is not just a concept but a future.

Keywords: Flywheel, Piezoelectric, Spring Gear

I. INTRODUCTION

A. Foot Step Power Generation:

The usage of traditional power generation method such as burning of coal, wood, diesel(generators) etc. is continuously depleting our natural resources such as fossil fuels, which is the demand for power has exceed the supply due to the rising population. In addition to this the traditional methods cause pollution.

B. Global Warming:

Global warming is the increase in the average measured temperature of the Earth's near-surface air and oceans since the mid-20th century, and its projected continuation. Global surface temperature increased 0.74 ± 0.18 °C (1.33 ± 0.32 °F) during the 100 years ending in 2005. The Intergovernmental Panel on Climate Change (IPCC) concludes that most of the increase since themed-twentieth century is "very likely" due to the increase in anthropogenic greenhouse gas concentrations. Natural phenomena such as solar variation combined with volcanoes probably had a small warming effect from pre-industrial times to 1950 and a small cooling effect from 1950 onward.

Climate model projections summarized by the IPCC indicate that average global surface temperature will likely rise a further 1.1 to 6.4 °C (2.0 to 11.5 °F) during the twenty-first century. This range of values results from the use of differing scenarios of future greenhouse gas emissions as well as models with differing climate

sensitivity. Although most studies focus on the period unto 2100, warming and sea level rise are expected to continue for more than a thousand years even if greenhouse gas levels are stabilized. The delay in reaching equilibrium is a result of the large heat capacity of the oceans.

Increasing global temperature is expected to cause sea levels to rise, an increase in the intensity of extreme weather events, and significant changes to the amount and pattern of precipitation, likely including an expanse of the subtropical desert regions. Other expected effects of global warming include changes in agricultural yields, modifications of trade routes, glacier retreat, mass species extinctions and increases in the ranges of disease vectors. Remaining scientific uncertainties include the amount of warming expected in the future, and how warming and related changes will vary from region to region around the globe. Most national governments have signed and ratified the Kyoto Protocol aimed at reducing greenhouse gas emissions, but there is on-going political and public debate worldwide regarding what, if any, action should be taken to reduce or reverse future warming or to adapt to its expected consequences. Global dimming, the gradual reduction in the amount of global direct irradiance at the Earth's surface, may have partially mitigated global warming in the late 20th century. From 1960 to 1990 human-caused aerosols likely precipitated this effect. Scientists have stated with 66–90% confidence that the effects of human-caused aerosols, along with volcanic activity, have offset some of the global warming, and that greenhouse gases would have resulted in more warming than observed if not for these dimming agents. Ozone depletion, the steady decline in the total amount of ozone in Earth's stratosphere, is frequently cited in relation to global warming. Although there are areas of linkage, the relationship between the two is not strong.

II. PROPOSED SYSTEM

These systems may generate voltage on each and every step of a foot. For this purpose, piezoelectric sensor is used in order to measure force, pressure and acceleration by its change into electric signals. This system uses voltmeter for measuring output, led lights, weight measurement system and a battery for better demonstration of the system.

- Whenever force is applied on piezoelectric sensor, then the force is converted into electrical energy.
- In that movement, the output voltage is stored in the battery
- The output voltage which is generated from the sensor is used to drive DC loads
- Here we are using AT89S52 to display the amount of battery get charged.

Android Based Home Automation

Dhirajkumar C. Ramteke¹ Pankaj S. Dhawale² Seema Biranware³

^{1,2}Student ³Assistant Professor

^{1,2,3}Department of Electronics Engineering

^{1,2,3}MPCE Bhilewada, Bhandara, 441904, India

Abstract— This Project presents the overall design of Home Automation System (HAS) with low cost and wireless remote control. This system is designed to assist and provide support so as to fulfill the needs of old age and physically challenged people at home. Also, the smart home concept in the system improves the standard of living at home. The main system implements Wireless Bluetooth technology to provide remote access from Smart Phone. The design has switches and provides more safety control features. All the Switches Status is synchronized with the Control System by every user interface indicates its real time status of each switches independently. This system is very useful to control electrical appliances and devices in house with relatively low-cost design, user friendly interface and straightforward for installation. Due to the advancement of wireless technology, there are several different connections are introduced such as GSM, WIFI, ZIGBEE, and Bluetooth. Each of the connection has their own unique specifications and applications. Among the four popular wireless connections that often implemented in HAS project, Bluetooth is being chosen with its suitable capability. Bluetooth with globally available frequencies of 2400Hz can provide connectivity up to 100 meters at speed of up to 3Mbps depending on the Bluetooth device class. Bluetooth wireless connection enabled the system communicates with graphical interface (GUI) on Android smart phone without cable. The target home appliances are controlled by the system Main Control Board in order improve the standard of living reception, this system provides physical control method to the Main Control Board is performed as wireless remote control to the appliances. The Bluetooth wireless connection enabled the system communicates with graphical user interface (GUI) on Android smart phone without cable. The user can easily touch on the screen of the phone to control the home appliances. This portable method can assist the physically challenged people who have problem with locomotion difficulty.

Keywords: GSM, Android, Home Automation, GUI

I. INTRODUCTION

The "Home Automation" concept has existed for many years. The terms "Smart Home", "Intelligent Home" followed and has been used to introduce the concept of networking appliances and devices in the house. Home automation Systems (HASs) represents a great research opportunity in creating new fields in engineering, architecture and computing (Humidor and Millan, 2004). HASs becoming popular nowadays and enter quickly in this emerging market. However, end users, especially the disabled and elderly due to their complexity and cost, do not always accept these systems. Due to the advancement of wireless technology, there are several different of connections are introduced such as GSM, WIFI, ZIGBEE,

and Bluetooth. Home automation refers to providing the capability to control as well as monitor various household activities. These may include lighting, heating and air conditioning, security locks on the doors, multimedia, and various appliances. Bluetooth board in their HAS project with cell phone remote control. This designed system remains the physical switches with the modified low voltage activating method, in order to provide safer physical control to the user compared to the conventional high voltage switches. The Bluetooth connection in this system is established by Bluetooth module that directly receives/transmits commands from/to smart phone. This system provides three different types of physical control methods to the Main Control Board. The first physical control method is by pressing on the modified Low Voltage Activating Switches. The conventional high voltages switches will be replaced by the modified 5 Volt push buttons as the activating switches. The low voltage switch eliminates the risk of dangerous electrical shock by wet hand. This control method is done by Android GUI installed in Smart Phone. The user can easily touch on the screen of the phone to control the home appliances. This portable method is able to assist the disabled people who have problem with locomotion difficulty. Android OS on Smart Phone is chosen based on the high user distribution in current market. By considering the flexibility, the main control board is designed with wired and wireless connection. USB HID as secondary connection to the control board performs the wired connection. For the wireless connection, the main control board can be connected to either one of the Smart Phone. Besides, the switches status on the board is synchronized in real time to all the connected GUI controllers. In term of cost, this system implemented low cost we are present, also with the help of an automatic room light control system, you need not worry about electricity as the lights get automatically off when there is no person. Microcontroller and Bluetooth module as the system main core. This system performs with powerful remote functions to make our life in home become easier. As the mobile devices are continuously increasing in its popularity and also for its smooth functionality the demand for advanced and responsive mobile applications is increasing day by day in people's daily routine. Smart home is not a new term for science society however; it is still far more away from people's vision and audition. The field of home automation is growing exponentially as the electronic based technologies are converging day by day. Variety of smart systems has been constructed where the control is through Bluetooth. Automatic Room Lights System using Arduino is a very useful project as you need not worry about turning on and off the switches every time you want to turn on the lights, In this project, we will see the Automatic Room Lights using Arduino and PIR Sensor, where the lights in

Voice Operated Wheel Chair For Physically Challenged

Pooja N. Karemore¹ Kimaya R. Moon² Kiran V. Vaidya³ Divya D. Rane⁴ Seema Biranware⁵

^{1,2,3,4}Student ⁵Assistant Professor

^{1,2,3,4,5}Department of Electronics and Telecommunication Engineering

^{1,2,3,4,5}MPCE Bhilewada, Bhandara, 441904, India

Abstract— The objective of this paper is to facilitate the movement of people who are disabled or handicapped and elderly people who are not able to move well. The result of this design will allow certain people to live a life with less dependence on others. Speech recognition technology is a key which may provide new way of human interaction with machines or tools. Thus the problem that they faced can be solved by using speech recognition technology to move the wheel chair. This can be realized with the Bluetooth as an intermediary. An interface is designed therefore to develop the program for recognizes s voice in turns control the movement of wheelchairs. The Arduino controls the wheelchair directions. Ultrasonic sensors are used to detect obstacles. The prototype is designed in such a way that it can be used independently and efficiently with less effort. It saves time, reduces cost and energy of the users.

Keywords: Arduino, Bluetooth, Speech recognition, Motor Driver

I. INTRODUCTION

In this project we are using Arduino and Voice Recognition System. Many people are with disabilities that need wheelchairs for their day to day life. Today's community few members of the disabled community find difficult or impossible for operating a standard power wheelchair. This project is included in assistive technology. For handicapped and disable people. This project provides more independent, productive and enjoyable living. To perform functions a handicapped person with movable disabilities needs a wheelchair that require him or her to move around. He/She can do so manually by pushing the wheelchair with his/her hands. However many of from disabled Community have weak hands to operate wheelchair efficiently. Therefore it is desirable to provide them with a motorized wheelchair which is controlled by moving a voice commands. Since motorized wheelchair is important that it be able to avoid obstacles automatically in real time, it can move at a fair speed, For this purpose we provide two separate motors who move wheelchair in all directions. The Cost of this motorized wheelchair is affordable for many handicapped people, as possible, as well as for organizations or NGOs that support it. With these requirements in mind we propose an automated wheelchair with real-time with better Herald avoidance capability. The power wheelchair control interfaces currently still not enough to provide mobility for substantial number of person with disabilities. Through research and design wise, the wheelchair to control development along safe and effective use of the provision independence and self use mobility. This project will provide innovative solutions for disabled people to handle the wheel chairs to use voice interface. This project describes a wheelchair which can be controlled only by using the user's voice. The main aim of this project is

to facilitate the movement of the disabled people and elderly people who cannot move properly so with this we can enable them to lead better lives without any problem. Speech recognition is a key technology which can provide human interaction with machines for controlling a wheelchair. This project includes basically two parts which is software and hardware. It is realized that for input of human voice we are using microphone with Bluetooth transmitter and receiver as an intermediary. In this project, Arduino kit (Atmega 328) is used as controller to control the movement of wheelchair based on the human voice as an input. There are five basic movements of a wheelchair to be applied by the user. The Five operations perform by the wheelchair are described as following:

- 1) Moving forward
- 2) Moving backward
- 3) Turning to the right
- 4) Turning to the left
- 5) Stop condition

II. SPEECH RECOGNIZATION

The speech recognition system is a completely assembled and easy to use programmable speech recognition circuit. Programmable, in the sense that you train the words (or vocal utterances) you want the circuit to recognize. This board allows you to experiment with many facets of speech recognition technology. It has 8 bit data out which can be interfaced with any microcontroller for further development. Some of interfacing applications which can be made are controlling home appliances, robotics movements, Speech Assisted technologies, Speech to text translation, and many more

III. PROPOSED SYSTEM

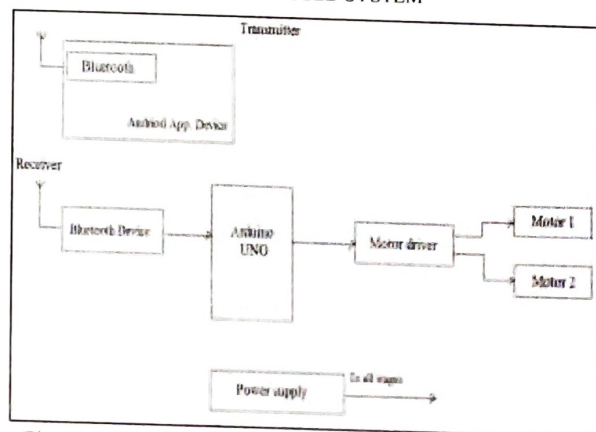

Fig. 1: Block Diagram Voice Operated Wheel Chair For Physically Challenged
The operator gives voice as input in order to drive the wheelchair to the desirable position. Mic which converts the

Electronic Protection for Exam Paper Leakage

Akash G. Baghele¹ Rishikumar S. Ukey² Vikas C. Mohare³ Shraddha M. Urkude⁴

^{1,2,3,4}BE Student

^{1,2,3,4}Department of Electronics and Telecommunication Engineering

^{1,2,3,4}MPCOE Bhilewada, Bhandara, India

Abstract— The Project describes Electronic protection for exam paper leakage which is a highly secured system. The examination is mainly the heart of the education system. We have proposed an electronic framework to distinguish and forestall test paper spillages. In this planned framework, the inquiry papers which are in the electronically bolted box will be sent to the assessment communities. The box will be opened after a predefined password only by an authorized user. As a matter of fact the inquiry papers are available in the sub boxes. These boxes are password protected. To open the individual sub boxes, the test regulator will communicate something specific alongside the secret phrase. If the password matches, only then the security gets disabled and he can open the box. Without entering any password if any one tries to open the box it will send SMS to higher authority about the illegal activity. In this framework we are utilizing a ringer for such unapproved impedance.

Keywords: Electronics Locked Box, OTP, 8051 Microcontroller, Modems

I. INTRODUCTION

Instruction is fundamentally the rousing power of the general public. An assessment is the evaluation intended to quantify the expertise, information, physical wellness or fitness and furthermore order in endless subjects. A test might be on paper, on the PC, orally, in test focuses, which are led to test, compute or inspect the arrangement of abilities. Likewise the fundamental reason for the assessment is to choose the competent contender for various positions.

For the understudies principle issues are question paper spillage, who experience the ill effects of the deferred or abrogation of the assessment. Every single year we hear news about delayed/dropped test because of paper spillages in the paper or on TV. Once in a while the college itself doesn't have the foggiest idea how there is spillage of any data content identified with question papers.

Hence, some student gets good rank in minimum time and with less effort and those students who really deserve the rank will not score even after hard work and maximum efforts. This viewpoint will make negative impact on understudies and dampen the development of society. So we have concocted a reduced and convenient arrangement and chose to plan and execute an assessment paper spillage insurance framework dependent on Microcontroller. Along with IC8051, GSM modem, Reed Switch is used in this system.

II. BLOCK DIAGRAM

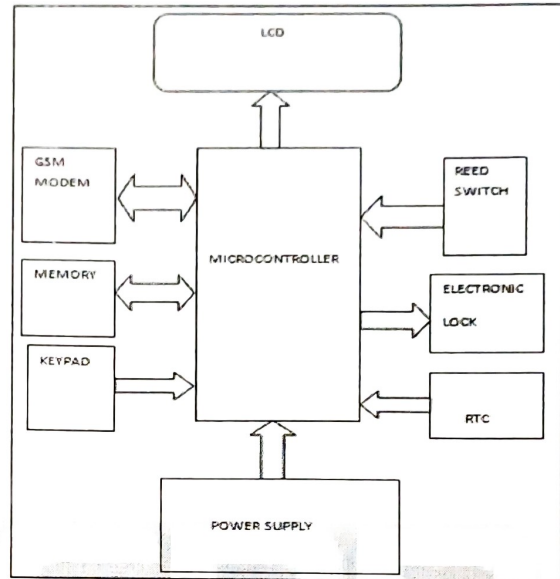

III. WORKING

First the inquiry paper goes to the school from college in an electronic fixed box which is called Electronic Control Box. The Electronic Control Box is an installed framework that was planned utilizing Microcontroller, which has inbuilt RTC to screen the Electronic Control Box. If anyone tries to open that box before and after the OTP time duration, the system communicates to the university authorities by sending an SMS (Short Message Service) through GSM (Global System for Mobile correspondence) that "some breaking down has occurred with the Electronic Control Box".

The college specialists send a remarkable secret phrase to the central authority of the school before 10 moment of the test. The system acknowledges for the password for 10 minutes valid time period. The same OTP will send to the ECB. Boss inspector needs to type the secret word which is given by the college utilizing the console. On the off chance that secret word is right, the electromagnet lock pivots and opens the Electronic Control Box. This framework has two handsets. The handset 1 is an implanted framework identified with the Electronic Control Box.

The handset 2 is the cell phone with the college specialists. The current module work manages the equipment and programming part. If the GSM password which is entered through keypad and that stored on E2PROM matches, then the stepper motor rotates to open the box. On the off chance that the school authority types an off-base secret key, at that point "Secret key MISMATCH" message is shown on the LCD. If anyone tries to open the